



# CASCADE — SERIES —

---

## CASCADE INSTALLATION GUIDELINES

---

### LUXURY RIGID CORE SPC FLOORING

**PLEASE READ ALL INSTRUCTIONS CAREFULLY BEFORE YOU BEGIN. IMPROPER INSTALLATION CAN VOID THE WARRANTY.**

#### TOOLS REQUIRED

- Utility Knife
- Tape Measure
- Straight Edge
- Spacers
- Tapping Block
- Pull Bar
- Moisture Testing Gauge
- Rubber Headed Mallet

Planks have attached UrbanShield Premium underlayment. Do NOT use additional underlayment under Cascade planks.

#### PRIOR TO INSTALLATION

- Carefully check flooring material for any defects. Contact your supplier immediately if any defect is found.
- Defective planks should NOT be installed.
- We recommend allowing the planks to acclimate 24 to 48 hours prior to installation in a climate-controlled job site (see recommended room temperatures below). Store boxes flat (never on edge), with box ends open to allow air flow, and no more than 3 to 5 boxes high.
- Room temperature between 65°F-85°F should be maintained for a minimum of 48 hours before, during, and after installation.
- Remove quarter round, baseboard molding or cove base.
- Undercut doorway moldings the thickness of the flooring.
- Cartons must be stored horizontally at all times (never on edge) to prevent warping and protect the locking systems. Stack no more than 5 boxes high.
- **Do not drop** - protect carton corners and edges from impact. Dropping boxes on edges can cause interior damage to the locking system.
- Prepare substrate.

#### WOOD SUBSTRATES

A wood subfloor must be smooth, flat and free of movement and deflection. If joist spacing is more than 19.2" on center, a minimum of ¾" total thickness of subfloor is required. A ¼" underlayment grade panel should be installed over wood subfloor if the surface of the subfloor is not smooth and flat.

Our warranties DO NOT cover any problems caused by inadequate substructures or improper installation of said substructures.

Recommended underlayments include:

APA Underlayment Grade Plywood A-C, B-C or C-C Plugged, ACCUPLY, SurePly, TECPLY, ULAY, C.S.A. (CanPly) and Proboard

Basements and crawl spaces should be kept dry and well ventilated. Crawl spaces must have a minimum of 18" from ground to underside of joists. Exposed earth should be kept 100% covered by a minimum of 6-8 mil black polyethylene vapor barrier and joints overlapped and sealed with a moisture resistant tape.

#### CONCRETE SUBSTRATES

**MOISTURE TEST REQUIRED:** Record the moisture content of the concrete substrate at the time of installation - **RETAIN THESE RECORDS.**

New concrete slab must cure for at least 90 days. Cascade SPC planks may be installed over on grade, above grade or below grade concrete subfloors. Concrete floors shall be constructed in accordance with the American Concrete Institute (ACI) 302.1 Guide for Concrete Floor and Slab Construction. Concrete shall be finished and cured according to ACI and have a minimum compressive strength of 3500 psi. Installation of moisture vapor barrier is recommended prior to pouring of on or below grade slabs. Moisture vapor transmission shall not exceed 8 lbs./1000 sq.ft./24 hours per ASTM F-1869 (Anhydrous Calcium Chloride Test). Moisture may also be tested according to ASTM F 2170 (Standard Test Method for Determining Relative Humidity in Concrete Floor Slabs Using in situ Probes). When tested according to this method, the internal relative humidity shall not exceed 85%. Cascade SPC planks may be installed over gypsum based underlayments.

#### EXISTING FLOORS

Cascade SPC planks may be installed over most existing smooth, single layer, hard surface or uncushioned resilient flooring. Check resilient flooring for any curled areas around the perimeter or at seams and repair if necessary. Use a good quality cementitious based embossing leveler to smooth and fill the existing floor. Do not install over carpet, cushioned backed resilient floor, or any floating or loose-laid flooring.

#### **⚠ WARNING**

Do not sand, dry sweep, dry scrape, drill, saw, bead-blast or mechanically chip or pulverize existing resilient flooring, backing, lining felt or asphaltic "cutback" adhesive. These products may contain asbestos Fibers or crystalline silica. Avoid creating dust. Inhalation of such dust is a cancer and respiratory tract hazard. Smoking by individuals exposed to asbestos Fibers greatly increases the risk of serious bodily harm. Unless positively certain that the product is a non-asbestos containing material, you must presume it contains asbestos. Regulations may require that the material be tested to determine asbestos content.

#### SUBSTRATE PREPARATION

- All substrates must be dry, clean, smooth, flat, free from all existing adhesive residues, and free from movement or deflection.
- Important: the substrate must be level within ¼" in a 10-ft. radius. Grind down any high spots and fill any low spots.
- Fill and level all plywood seams and concrete cracks, grout lines, embossed patterns, construction joints, control joints, depressions, grooves or other irregularities. Use a latex fortified, cementitious patching compound.
- Sweep and/or vacuum substrate to remove all dust and debris.

#### GETTING STARTED

- Cascade is a floating floor and should not be glued or nailed to the substrate.
- Cascade SPC planks are intended for indoor use only.
- Determine in which direction the planks will be installed.

NOTE: To make the room appear larger, or if installing in very small rooms or hallways, it is preferable to lay the planks parallel to the longest room dimension.

- Do not install cabinets on top of Cascade SPC planks.
- Carefully measure the room to determine squareness and also to determine the width of the last row of planks. If the width of the last row of planks is less than 2" (50mm), excluding the tongue, the width of first row of planks will have to be cut and adjusted accordingly.
- A minimum  $\frac{5}{16}$ " (8.2mm) expansion space is required around the perimeter of the room and all vertical objects.
- Inspect all planks for visible defects and damage before and during installation. **Do not install damaged planks.** Urbanfloor will not accept responsibility for claims on flooring installed with obvious defects. During installation, inspect the groove area of the plank and remove any debris that may prevent proper assembly of planks.
- A wide variation in color and texture is designed into this product to enhance its natural appearance. Pull alternate planks from a minimum of 5 boxes to blend the variations for the best natural appearance.
- Moldings are designed to color coordinate with the overall look of the floor. Due to the many color and texture variations designed into each plank, 'exact matches' are not possible. Color and texture variations between planks and moldings are not considered defective.

## INSTALLATION

1. Begin laying planks from the left side of the starting wall and work to the right side. **The tongue side of the plank should face the starting wall, groove side should face out.**
2. Place  $\frac{5}{16}$ " (8.2mm) spacers between the short and long side of the planks and the wall. Always position one spacer between the wall and where the planks' end joints meet (See D2 & D3).
3. The end joints of the planks in the **first row** are assembled by inserting the tongue side into the groove side of the previous plank at a low angle. Gradually lower the plank down flat until the end joint closes, ensuring that the planks are perfectly aligned, smooth, and level. If necessary, use a mallet and tapping block to gently tap down on the ends to firmly lock in the end joints. It is important to ensure that both the plank ends are perfectly aligned and level with each other. DO NOT strike plank directly on the surface as this can cause damage to the finish. Use the tapping block. Install remaining full planks in first row (see D2, D3, and D8).
4. The last plank in the first row will need to be cut. Measure the distance between the wall and the surface of the last full plank. Subtract  $\frac{5}{16}$ " (8.2mm) from this measurement to allow for the spacer. If this measurement is less than 8" (20.3cm), the length of first plank in the row must be cut. This will allow for a longer plank at the end of the row. The first and last plank in each row must be at least 8" (20.3cm) in length. Planks can be cut using a table saw or scored and snapped using a straight edge and utility knife. Score the top surface of the plank a few times with a utility knife then snap the plank on score line. It may be necessary to then cut through the attached underlayment.
5. The remaining piece cut off from the last plank in the first row may serve as the first plank in the second row provided it is at least 8" (20.3cm) long (See D5). Always stagger end joints from row to row a minimum of 8" (20.3cm).
6. Install the long side of the **first plank** of the **second row**. Remember to place a  $\frac{5}{16}$ " (8.2mm) spacer between the wall and the short side of the plank. Insert the tongue side into the groove side of the previous row at a low angle and lower flat to the substrate (See D5).
7. Install the **second plank** in the **second row**. Position the long side of the plank with the tongue side overlapping the groove of the planks in the previous row approximately  $\frac{1}{8}$ ".
8. Angle the end joint into the previous plank. Angle the plank up and gently push forward until the plank locks into the previous row. Continue

installing remaining planks in second row. **It is important to make sure that the first two rows are straight and square as they can affect the entire installation.** After installing each row, use a rubber mallet and tapping block to gently tap the plank joints into the joints of the previous row to ensure a tight fit and perfect alignment between end and side joints. Any gapping or misalignment can affect the quality of the installation (See D5).

9. The last board in each row should be cut to fit the end of the row, while still maintaining the  $\frac{5}{16}$ " expansion gap at the wall (See D6 & D7). Here's how:
  - (1) Flip the board over (placing the groove to your left).
  - (2) Measure the board to the size of the gap in the row.
  - (3) Mark and cut the board using a miter or table saw or score and snap.
  - (4) Flip the board over and it will be ready to insert and be tapped into place.
  - (5) You may use the remaining piece to begin the next row.
10. Use a pull bar to lock in the last plank of a row and in the last row of flooring being installed in the room.
11. Continue working from left to right, row by row. Be sure to maintain a  $\frac{5}{16}$ " space around all walls and vertical objects and maintain a random appearance. Offset end joints a minimum of 8" (20.3cm) from row to row.

## RADIANT HEAT SUBFLOORS

This product can be installed over radiant heated subfloors. The heating elements must be embedded into the subfloor and must have a minimum 1/2" separation from the Cascade flooring. Electric heating mats not embedded into subfloor are not recommended. The radiant heated subfloor should be fully operating at normal temperature for minimum of 21 days prior to floor installation to dry out any residual moisture. The system should then be turned off 24 hours prior to installation and remain off for 24 hours after installation. After 24 hours the temperature can be gradually raised again of a 7-day period to desired temperature. The MAX allowable subfloor surface temperature over radiant heat is 85°F.

## FINISHING THE INSTALLATION

- After all planks have been installed, remove spacers from perimeter of room.
- Install any transition moldings. Do not fasten any moldings through the flooring.
- Predrill and install quarter round or baseboard molding. Molding must be sufficient size to cover the  $\frac{5}{16}$ " (8.2mm) space. Do not fasten moldings through the flooring. Fasten into the wall.
- Use a  $\frac{1}{8}$ " Masonite sheet to cover and protect the top of the flooring when moving heavy furniture or appliances into position.
- Use proper floor protectors under the legs of furniture.
- Post installation room temperature MUST be maintained between 65° F and 100° F (flooring temperature) Relative humidity must be maintained between 40% and 70%.
- Place walk-off mats at all doors leading to exteriors to help prevent tracking of grit, dirt, and sand.

## A NOTE ON MOLDINGS

Pre-drill and install quarter round and/or baseboard moldings. Molding must be of sufficient thickness to cover the required expansion space. **DO NOT FASTEN MOLDINGS TO THE FLOORING but rather attach to the wall.** Ensure that there is adequate space between the bottom of the molding and the flooring to allow it to freely expand and contract.

## INSTALLING CASCADE PLANKS ON STAIRS

When installing on stairs, it is required that the planks are directly glued down to the stair surface. **FIRST**, the 1mm black underlayment backing **MUST BE REMOVED** (simply peel off the backing).

Use only an adhesive that is specially formulated for installing vinyl tile or LVT

planks. Follow adhesive manufacturer instructions carefully.

## MAINTENANCE

Please follow the recommendations in this guide to retain the fresh look and protect the finish.

- Sweep or vacuum the floor regularly. Use a vacuum designed for hard surfaces (if vacuum has a beater bar, it should be turned off).
- Wipe off any spills with clean water and a damp (not wet) mop. Use a dry mop to remove surplus water and then allow to dry.
- Use cleaners recommended for vinyl flooring. Do not use polishes, waxes, abrasive or ammonia based cleaners. The surface is dense and non porous which prevents cleaners from penetrating and this can build up a residue on the surface which will collect dirt. Please check any new cleaning agent on a small test patch of the floor in an inconspicuous area.

Immediately after installation of the floor, we recommend a first cleaning to remove any dirt and debris caused by the installation process. Follow instructions above.

Pets with unclipped nails can damage your flooring. The same is true for any high-heeled shoes that do not have proper tips on the heels.

## GENERAL CARE & MAINTENANCE TIPS

### Environmental Factors

Avoid exposure to direct sunlight for prolonged periods of time. During peak sunlight hours, use drapes or blinds to minimize the direct sunlight on the flooring. Most types of flooring will be affected by continuous strong sunlight. In addition, excessive temperatures are not good for resilient floors. Some natural ventilation or intermittent air conditioning in vacant homes should be considered. Long term continuous inside temperatures over 95°F combined with strong direct sunlight will damage the flooring and cause the installation to fail.

If your floor has been exposed to excessive amounts of water due to flooding, Cascade SPC planks are waterproof. Simply remove the water as quickly as possible. A dehumidifier should be promptly turned on in the room to reduce the moisture levels back to normal. Do not dry the room below the normal moisture level that existed previously.

### Dog & Animal Care

Keep nails clipped. Dogs running through the house can scratch any finish. Put a mat down to stand between your pet's water dish and your floor.

### Area Rug Backings

Only rugs with a natural backing (i.e., felt) are safe for Cascade flooring. Avoid rugs with a rubber or abrasive backing, as these can damage or discolor a floor.

### Floor Protectors

Use felt protectors under legs of chairs and furniture. Non-abrasive, felt-backed products are best. Rubber or plastic products can damage and discolor your floor. Caster wheeled chairs are not recommended as, over time, they can damage your SPC flooring.

### Removing Scuff Marks

If scuff marks cannot be removed using a damp rag, stubborn scuffs can be removed by the use of a tennis ball or pencil eraser. Gently rub in long direction of plank.

### Floor Cleaning

During the cleaning process, rinse applicator often in a separate pail of clean water. A dirty applicator can spread dirt to other areas, causing streaks and haziness. Remember: use a damp (never wet) applicator – squeeze out surplus water and ensure that the residual water evaporates from the floor within one minute. If it takes longer, there is too much moisture on the applicator.

### Moving Appliances

When moving heavy items, such as appliances, slide a ½" Masonite sheet under the heavy objects to prevent floor damage.

VISIT OUR WEBSITE: [WWW.URBANFLOOR.COM](http://WWW.URBANFLOOR.COM)  
FOR ANY RECENT UPDATES OF INSTALLATION GUIDELINES

Cascade SPC products are distributed through Urbanfloor.  
Call Urbanfloor technical department with any questions or concerns.



Technical Department  
3707 Capitol Ave., City of Industry, CA 90601  
323.890.0000 • 866.75.URBAN • [info@urbanfloor.com](mailto:info@urbanfloor.com)

*Last update: 4/27/21*

# HOW TO ASSEMBLE TONGUE AND GROOVE PLANKS

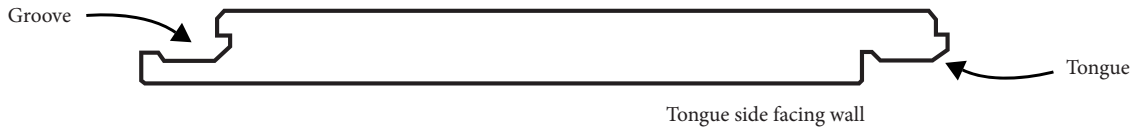

Note: Diagram is for illustration purposes only. The actual design of the tongue and groove of your floor may be different.

D1

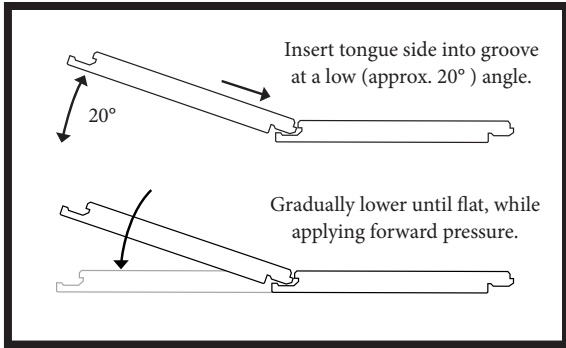

D2

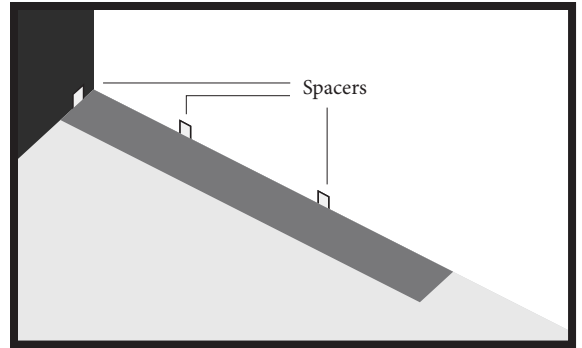

D3

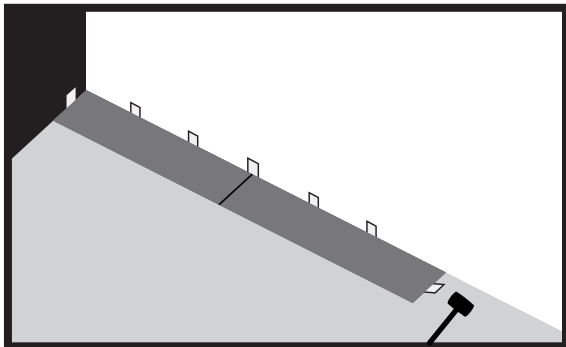

D4

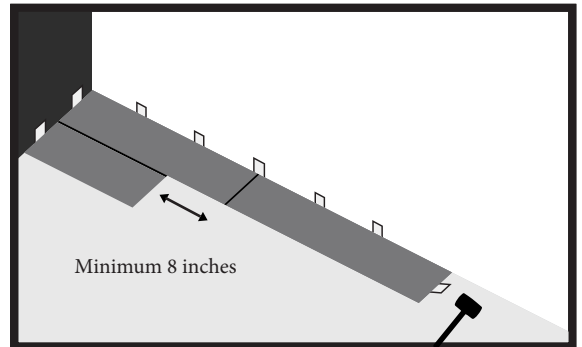

D5

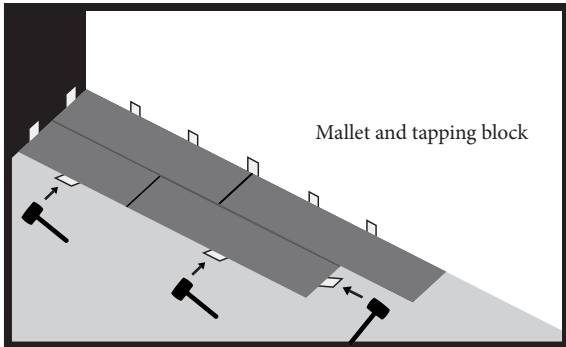

D6

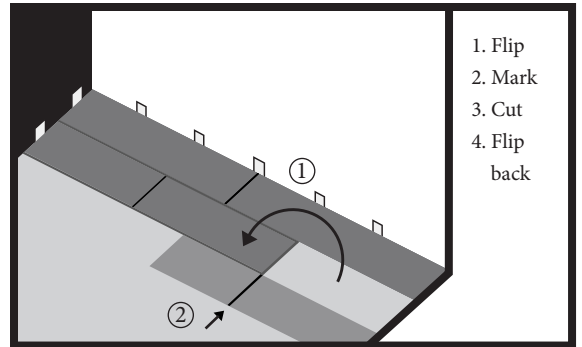

D7

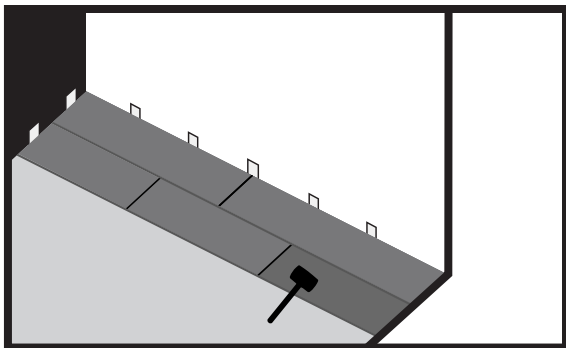

D8

